



SX421 AUTOMATIC VOLTAGE REGULATOR (AVR)

SPECIFICATION, INSTALLATION AND ADJUSTMENTS

General description

SX421 is a three phase sensed Automatic Voltage Regulator and forms part of the excitation system for a brush-less generator.

In addition to regulating the generator voltage, the AVR circuitry includes a number of other useful features. Excitation power is derived directly from the generator terminals.

Positive voltage build-up from residual levels is ensured by the use of efficient semiconductors in the power circuitry of the AVR.

The AVR senses the voltage in the main generator winding and controls the power fed to the exciter stator and hence the main rotor to maintain the generator output voltage within the specified limits, compensating for load, speed, temperature and power factor of the generator.

A frequency measuring circuit continually monitors the speed of the generator and provides under-speed protection of the excitation system by reducing the generator output voltage proportionally with speed below a pre-settable threshold. A further enhancement of this feature is an adjustable volts per Hertz slope, to improve the response of turbo charged engines.

The AVR includes a stator over-voltage protection feature that directly trips a miniature circuit breaker to break the excitation circuit.

Provision is made for the connection of a remote voltage trimmer, allowing the user fine control of the generator's output.

An analogue input is provided allowing connection to a Newage Power Factor controller or other external device with compatible output.

The AVR has the facility for droop CT connection, to allow parallel running with other similarly equipped generators.

Technical specification

SENSING INPUT

Voltage 190-264V ac max, 2 or 3 phase.
Frequency 50-60 Hz nominal

POWER INPUT

Voltage 190-264 Vac max, 3 phase only.
Frequency 50-60 Hz nominal

OUTPUT

Voltage max 90V dc at 207V ac input
Current continuous 4 A
Intermittent 6A for 10 secs.
Resistance 15 ohms minimum

REGULATION

+/- 0.5% RMS (see note 1)

THERMAL DRIFT

0.02% per °C change in AVR ambient (note 2)

TYPICAL RESPONSE

AVR response 20 ms
Filed current to 90% 80 ms
Machine Volts to 97% 300 ms

EXTERNAL VOLTAGE ADJUSTMENT

+/-10% with 5 k ohm 1 watt trimmer (see note 3)

UNDER FREQUENCY PROTECTION

Set point 95% Hz (see note 4)
Slope 100-300% down to 30 Hz

UNIT POWER DISSIPATION

20 watts maximum

BUILD UP VOLTAGE

4V ac @ AVR terminals

ANALOGUE INPUT

Maximum input +/- 5V dc (see note 5)
Sensitivity 1v for 5% Generator Volts
(adjustable)

Input resistance 1k ohm

QUADRATURE DROOP INPUT

10 ohms burden
Max. sensitivity: 0.22 A for 5% droop 0PF
Max. input: 0.33 A

OVER VOLTAGE DETECTOR INPUT (see note 6)

Set point: 300v. Time delay: 1 Sec (fixed)
CB trip coil volts: 10-30V dc
CB trip coil resistance: 20-60 ohms

ENVIRONMENTAL

Vibration	20-100 Hz	50mm/sec
	100Hz – 2kHz	3.3g
Operating temperature	-40 to +70°C	
Relative Humidity	0-70°C 95% (see note 7)	
Storage temperature	-55 to +80°C	

NOTES

- | | |
|---|--|
| <ol style="list-style-type: none"> 1. With 4% engine governing. 2. After 10 minutes. 3. Applies to Mod status C onwards. Generator de-rate may apply. Check with factory. 4. Factory set, semi-sealed, jumper selectable. | <ol style="list-style-type: none"> 5. Any device connected to the analogue input must be fully floating (galvanically isolated from ground), with an insulation strength of 500V ac. 6. A miniature circuit breaker must be fitted to use the over voltage protection feature. 7. Non condensing. |
|---|--|

DESIGN DETAIL

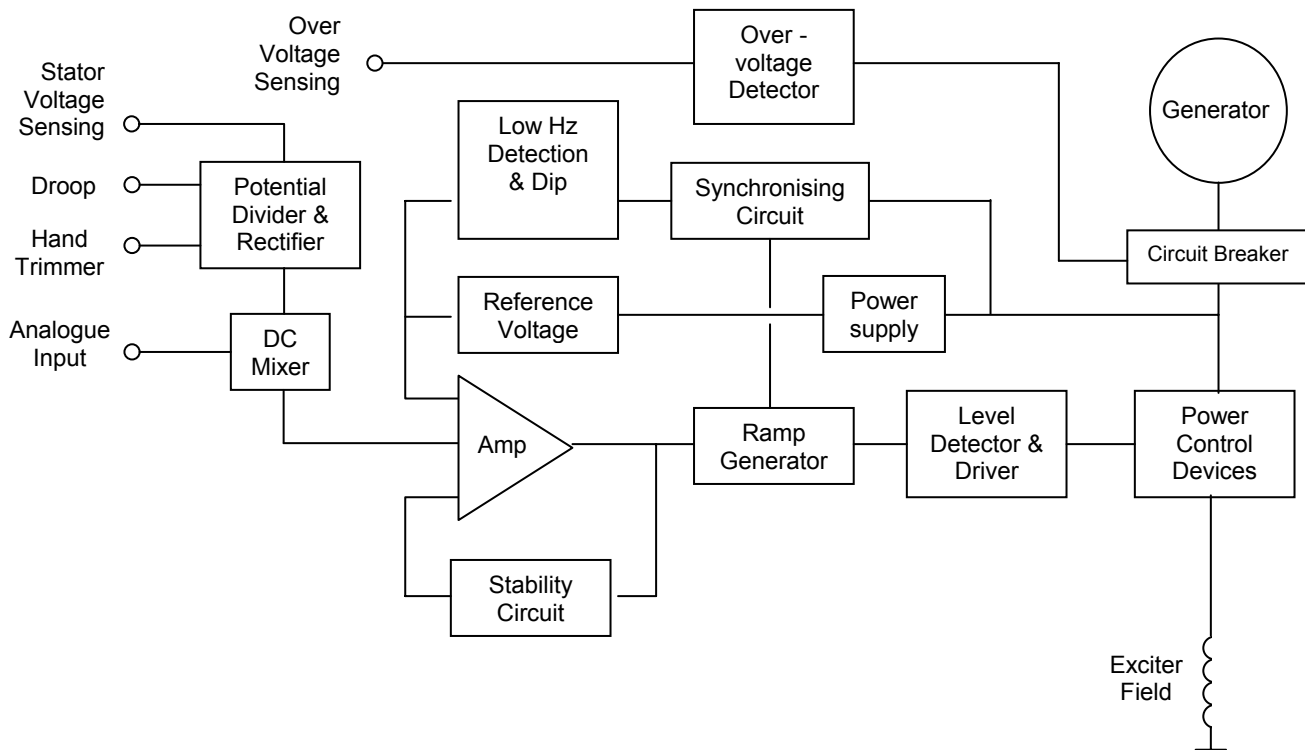

The main functions of the AVR are:

Potential Divider and Rectifier takes a proportion of the generator output voltage and attenuates it. The potential divider is adjustable by the AVR Volts potentiometer and external hand trimmer (when fitted). The output from the droop CT is also added to this signal. A rectifier converts the a.c. input signal into a d.c. signal representing generator voltage.

The DC Mixer adds the Analogue input signal the generator voltage signal.

The Amplifier (Amp) compares the generator voltage signal to the Reference Voltage and amplifies the difference (error) to provide a controlling signal for the power devices. The Ramp Generator and Level Detector and Driver infinitely control the conduction period of the Power Control Devices and hence provides the excitation system with the required power to maintain the generator voltage within specified limits.

The Stability Circuit provides adjustable negative ac feedback to ensure good steady state and transient performance of the control system.

The Power Supply provides the required voltages for the AVR circuitry.

The Low Hz Detector measures the period of each electrical cycle and causes the reference voltage to be reduced approximately linearly with speed below a presettable threshold. The Dip circuit provides adjustment for greater voltage roll off. A Light Emitting Diode gives indication of underspeed running.

The Synchronising circuit is used to keep the Ramp Generator and Low Hz Detector locked to the Generator waveform period.

Power Control Devices vary the amount of exciter field current in response to the error signal produced by the Amplifier.

The Circuit Breaker provides circuit isolation of the control system in the event of an over voltage condition.

The Over Voltage Detector continuously monitors the generator stator voltage and sends a trip signal to the Circuit Breaker if this rises above the reference level, for greater than the stated time period.

FITTING AND OPERATING (Refer to generator wiring diagram for connection details)

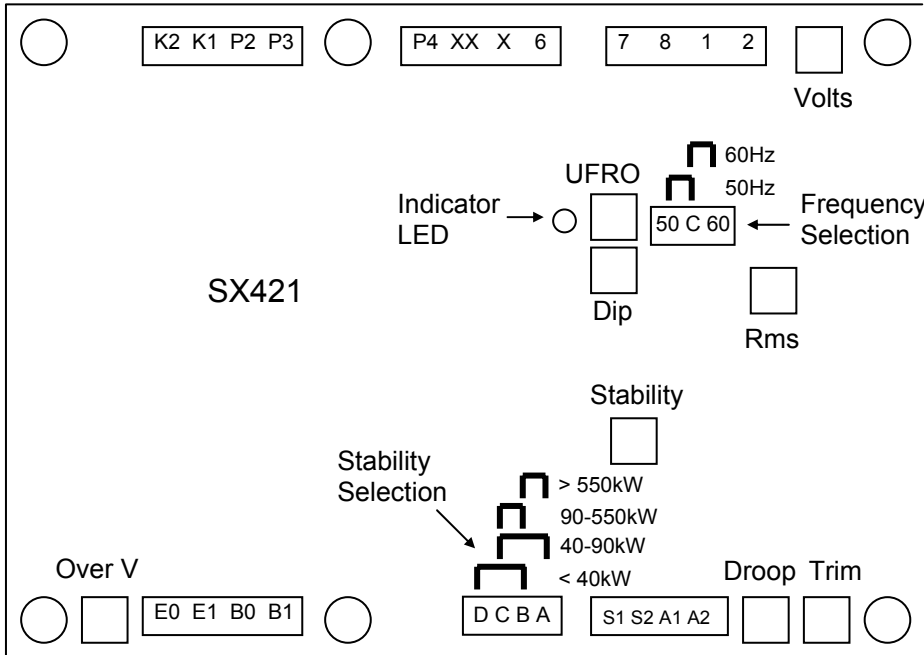

SUMMARY OF AVR CONTROLS

CONTROL	FUNCTION	DIRECTION
VOLTS	TO ADJUST GENERATOR OUTPUT VOLTAGE	CLOCKWISE INCREASES OUTPUT VOLTAGE
STABILITY	TO PREVENT VOLTAGE HUNTING	CLOCKWISE INCREASE THE DAMPING EFFECT
UFRO	TO SET THE UFRO KNEE POINT	CLOCKWISE REDUCES THE KNEE POINT FREQUENCY
DROOP	TO SET THE GENERATOR DROOP TO 5% AT 0PF	CLOCKWISE INCREASES THE DROOP
TRIM	TO OPTIMISE ANALOGUE INPUT SENSITIVITY	CLOCKWISE INCREASES THE GAIN OR SENSITIVITY
DIP	TO SET THE HZ RELATED VOLTAGE DIP	CLOCKWISE INCREASES THE DIP
OVER V	TO SET THE OVER VOLTAGE TRIP LEVEL	CLOCKWISE INCREASES THE TRIP LEVEL

ADJUSTMENT OF AVR CONTROLS

VOLTAGE ADJUSTMENT

The generator output voltage is set at the factory, but can be altered by careful adjustment of the VOLTS control on the AVR board, or by the external hand trimmer if fitted. Terminals 1 and 2 on the AVR will be fitted with a shorting link if no hand trimmer is required.

CAUTION Do not increase the voltage above the rated generator voltage. If in doubt, refer to the rating plate mounted on the generator case.

CAUTION Do not ground any of the hand trimmer terminals, as these could be above earth potential. Failure to observe this could cause equipment damage.

If a replacement AVR has been fitted or re-setting of the VOLTS adjustment is required, proceed as follows:

1. Before running generator, turn the VOLTS control fully anti-clockwise.
2. Turn remote volts trimmer (if fitted) to midway position.
3. Turn STABILITY control to midway position.
4. Connect a suitable voltmeter (0-300V ac) across line to neutral of the generator.
5. Start generator set, and run on no load at nominal frequency e.g. 50-53Hz or 60-63Hz.
6. If the red Light Emitting Diode (LED) is illuminated, refer to the Under Frequency Roll Off (UFRO) adjustment.
7. Carefully turn VOLTS control clockwise until rated voltage is reached.
8. If instability is present at rated voltage, refer to stability adjustment, then re-adjust voltage if necessary.
9. Voltage adjustment is now completed.

FITTING AND OPERATING (Refer to generator wiring diagram for connection details)

STABILITY ADJUSTMENT

The AVR includes a stability or damping circuit to provide good steady state and transient performance of the generator.

A jumper link selector is provided to optimise the response of the stability circuit to various size generators. The link should be positioned as shown in the diagram according to the kW rating of the generator.

The correct setting of the Stability adjustment can be found by running the generator at no load and slowly turning the stability control anti-clockwise until the generator voltage starts to become unstable. The optimum or critically damped position is slightly clockwise from this point (i.e. where the machine volts are stable but close to the unstable region).

UNDER FREQUENCY ROLL OFF (UFRO) ADJUSTMENT

The AVR incorporates an underspeed protection circuit which gives a volts / Hz characteristic when the generator speed falls below a presettable threshold known as the "knee" point. The red Light Emitting Diode (LED) gives indication that the UFRO circuit is operating.

The UFRO adjustment is preset and sealed and only requires the selection of 50 or 60Hz and 4 pole or 6 pole, using the jumper link as shown in the diagram.

For optimum setting, the LED should illuminate as the frequency falls just below nominal, i.e. 47Hz on a 50Hz system or 57Hz on a 60Hz system.

DROOP ADJUSTMENT

Generators intended for parallel operation are fitted with a quadrature droop C.T. which provides a power factor dependent signal for the AVR. The C.T. is connected to S1, S2 on the AVR, (see generator wiring diagram for details). The DROOP adjustment is normally preset in the works to give 5% voltage droop at full load zero power factor.

Clockwise increases the amount of C.T. signal injected into the AVR and increases the droop with lagging power factor ($\cos \phi$). With the control fully anti-clockwise there is no droop.

TRIM ADJUSTMENT

An analogue input (A1 A2) is provided to connect to the Newage Power Factor Controller or other devices. It is designed to accept dc signals up to +/- 5 volts.

CAUTION Any devices connected to this input must be fully floating and galvanically isolated from ground, with an insulation capability of 500 Vac. Failure to observe this could result in equipment damage.

The dc signal applied to this input adds to the AVR sensing circuit. A1 is connected to the AVR 0 volts. Positive on A2 increases excitation. Negative on A2 decreases excitation. The TRIM control allows the user to adjust the sensitivity of the input. With TRIM fully anti-clockwise the externally applied signal has no effect. Clockwise it has maximum effect.

Normal setting is fully clockwise when used with a Newage Power Factor Controller.

DIP ADJUSTMENT

This feature is mostly used when the generator is coupled to turbo charged engines with limited block load acceptance. The feature works by increasing the V/Hz slope to give greater voltage roll off in proportion to speed. With the DIP control fully anti-clockwise, the generator voltage will follow the normal V/Hz line as the speed falls below nominal. Turning the DIP control clockwise provides greater voltage roll off aiding engine recovery.

OVER VOLTAGE (OVER V) ADJUSTMENT

This adjustment is set and sealed in the works and should not be tampered with. An over voltage condition is indicated by the illumination of the red LED which also indicates under-speed running and over-excitation.

The generator must be stopped to reset an over-voltage trip.